

3150L Series 3 plungers 150 HP (110 Kw)

- Input shaft to left (I) or right viewable from the head.
- Auxiliary P.T.O. shaft on opposite side.
- Internal gear box with reduction 2,963 in 3150 body type. Reduction 3,652 in 3150R type.
- Internal oil pressure lubrication. Carter 3150 E / 3150R E.
- Stroke: 95 mm.
- Ceramic plungers.
- Very high pressure head L type, inline valves, optimal pressure resistant.
- Internal parts in contact with the liquid made of resistant corrosion materials.
- Accessories, pressure regulator valve, safety valve, manometer, outlet nipples.

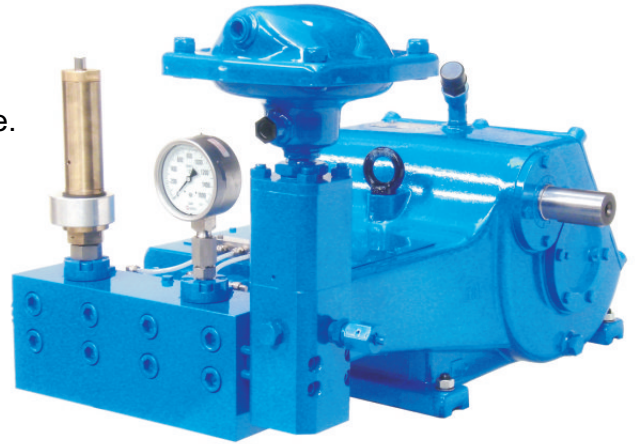

ROSTOR 3150L LAD3N

Technical data

Plunger (mm)	Shaft (r.p.m.)	Reduction	Crank shaft (r.p.m.)	Q (l/min)	Motor power (HP / Kw)				
					75/55	100/75	125/90	150/110	
					Working pressure (bar)				
HEAD L	16	1500	2,963	506	28	1020	1360	1500	-
		1800	3,652	493	26	1050	1440	1500*	-
		1500	3,652	411	22	1250*	1500*	-	-
	18	1500	2,963	506	35	805	1075	1340*	1500*
		1800	3,652	493	34	830	1100	1380*	1500*
		1500	3,652	411	28	995	1340*	1500*	-
	20	1500	2,963	506	43	650	870	1090	1300
		1800	3,652	493	41	680	910	1140	1300
		1500	3,652	411	35	800	1070	1300*	-
	22	1500	2,963	506	52	540	720	900	1000*
		1800	3,652	493	50	550	750	940	1000*
		1500	3,652	411	42	665	890	1000*	-
24	1500	2,963	506	62	450	605	750	900*	
	1800	3,652	493	60	465	620	780	900*	
	1500	3,652	411	50	555	750	900*	-	
26	1500	2,963	506	73	385	515	640	750*	
	1800	3,652	493	71	395	530	660	750*	
	1500	3,652	411	59	475	635	750*	-	
30	1500	2,963	506	97	290	390	480	570*	
	1800	3,652	493	94	300	400	500	570*	
	1500	3,652	411	78	355	475	570	-	

* To obtain this pressure is needed less power than indicated.

Crankshaft speed to 413 r.p.m. or inferior for intensive use, the rest intermittent use.

Weight: 335 Kg

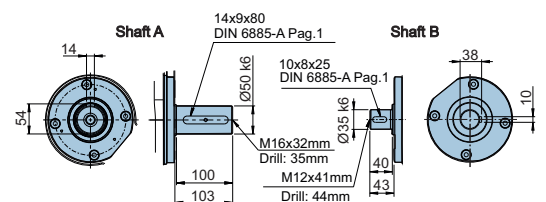
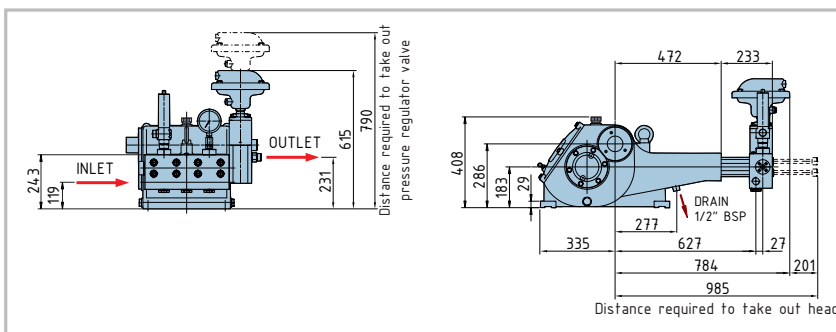
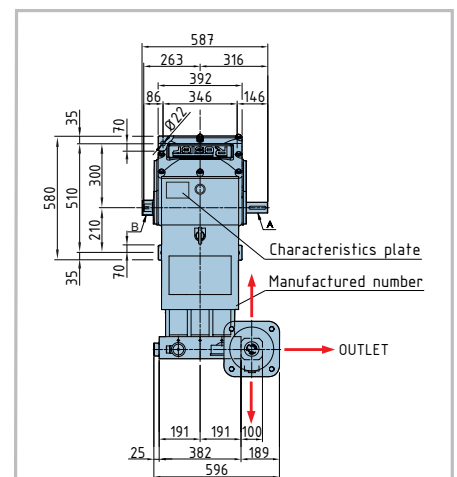

ROSTOR 3150L LDA3N

With: Pressure regulator valve LAD3N, safety valve and manometer



HIGH PRESSURE PUMPS

3150L Series 3 plungers 150 HP (110 Kw)



3150L - 150 HP
1.250 bar - 42 l/min

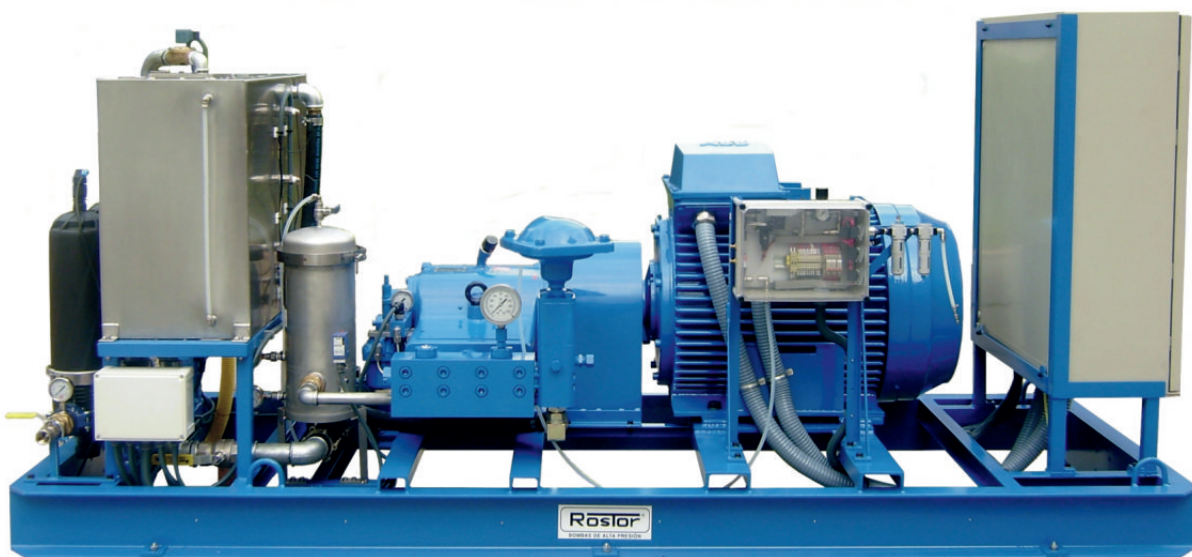

3150E L26 - 150 HP
750 bar - 73 l/min